

# VIDEOMARCADOR 2 MODULOS

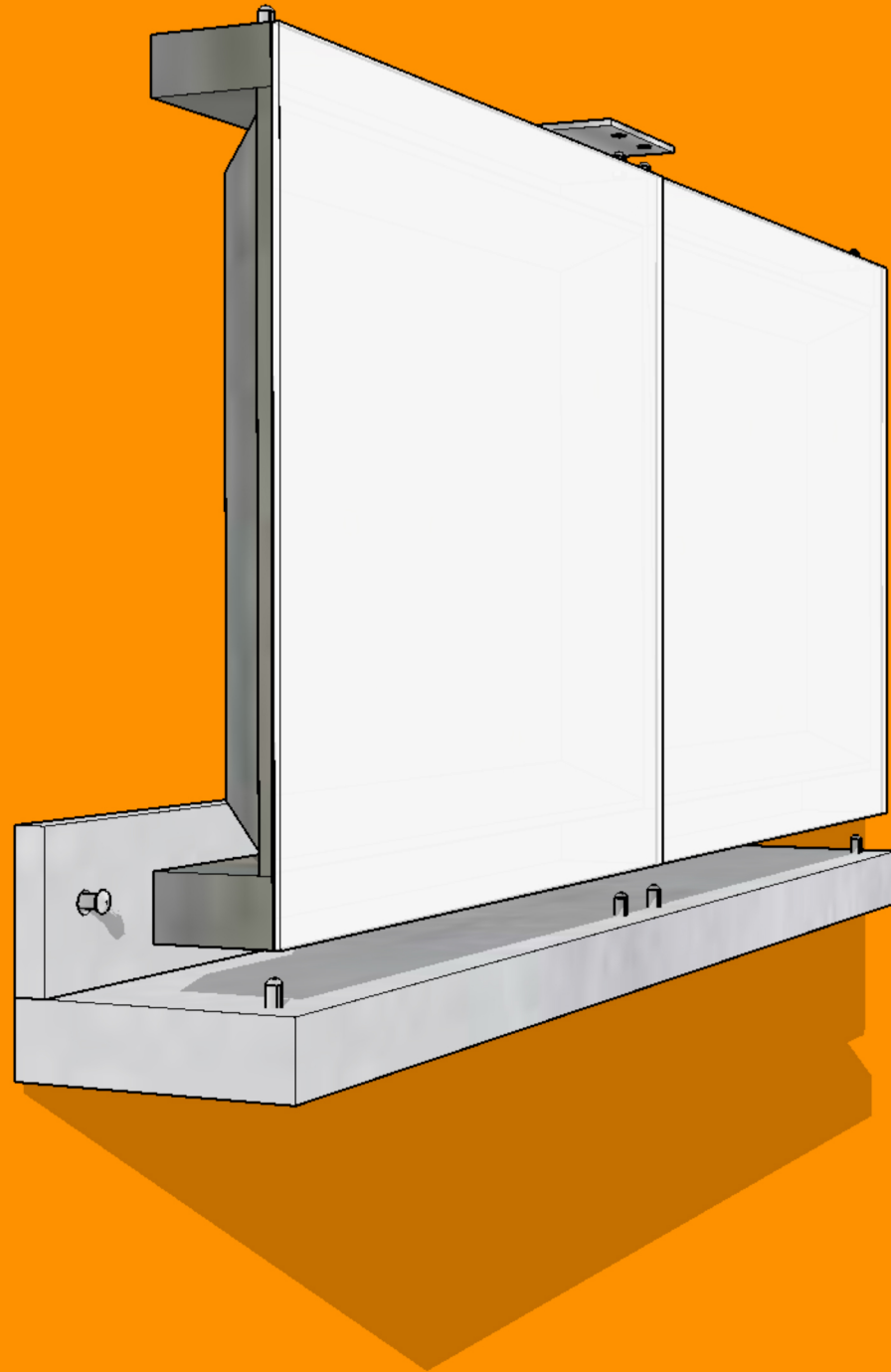

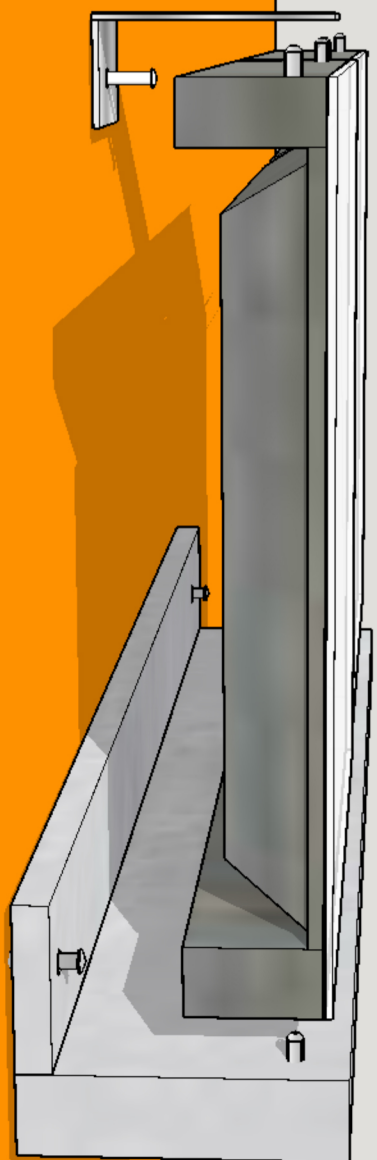



**VIDEOMARCADOR DIMENSIONES UN MÓDULO**  
**PESO: 11KG**

FRENTE

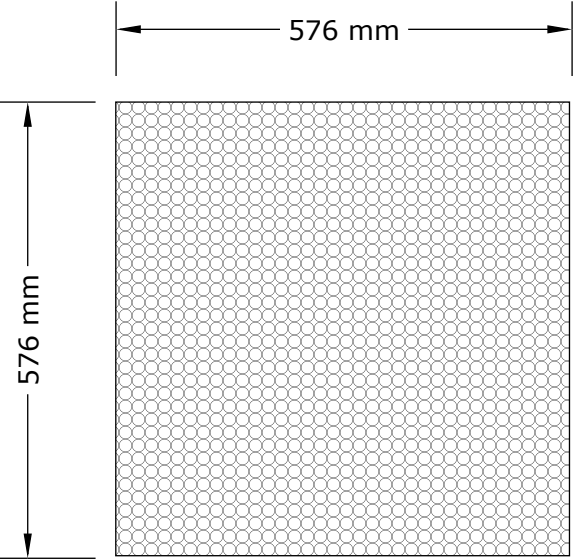

VISTA LATERAL

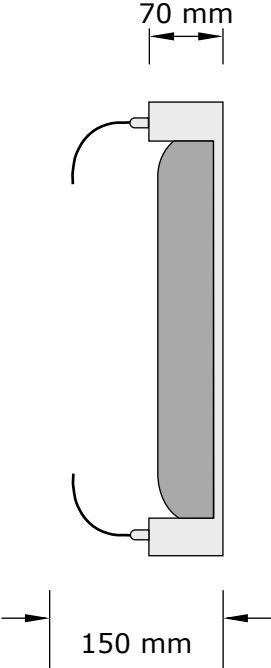

PANEL POR DETRAS

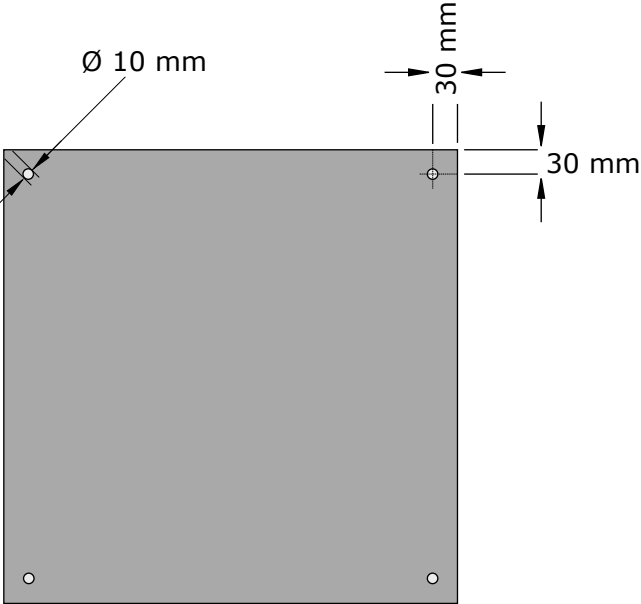

PLANTA

